

SERIES 'MES' SELF-PRIMING MAGNETIC COUPLED PUMPS



Versatile-Economical

- **Flows to 54 GPM or 63 ft. TDH @ 60 Hz**
(172 LPM or 13.6 m @ 50 Hz)
- **Non-metallic solution contact**
Glass reinforced polypropylene or
Carbon reinforced PVDF
(See a chemical resistance chart)
- **Deep-lift capacity**
Up to 25 feet / 7.6 meters
- **Fast priming**
18 feet / 4.6 meters in 90 sec.
- **Extended dry run capability**
- **Powerful rare earth magnets**
Provide sure coupling to 1.8 S.G.
- **Accepts standard motors**
NEMA or IEC metric

Series 'MES' self-priming magnetic coupled pumps are seal-less and "leak-proof" providing total solution containment. They are available in a choice of two different corrosion resistant materials for a wide range of chemical and temperature compatibility and are ideal for handling even the most difficult applications.

The outstanding self-priming feature of the Series 'MES' combines deep-lift capabilities (up to 25 feet / 7.6 meters) and lightning-fast priming (18 feet / 4.6 meters in 90 seconds). The priming chamber's gooseneck design eliminates the need for internal check valves while ensuring that enough liquid is retained for efficient re-priming.

These pumps utilize powerful rare earth, neodymium, magnets which allow them to operate at full flow with a full size impeller while handling liquids over 1.8 specific gravity.

Additionally the Series 'MES' has extended dry run capability when equipped with the standard carbon bushing and under optimum operating conditions. This helps protect the pump from operator errors and system upsets.

Their innovative and highly efficient design, and low energy consumption make these pumps one of the most versatile and economical centrifugal pumps on the market.

SPECIFICATIONS / PERFORMANCE

Standard models are constructed of glass-fiber reinforced polypropylene or carbon-fiber reinforced PVDF for suction casing, magnet liner and impeller. Impeller magnets are encapsulated in unfilled polypropylene or unfilled PVDF. The front and rear thrust rings and shaft are high purity, fluoride resistance alumina ceramic.

The impeller thrust ring is molybdenum disulfide filled PTFE. The casing 'O'-ring is FKM. Maximum pump pressure; 80 PSI (5.5 bar). Motors are continuous-duty and have a 1.5 service factor.

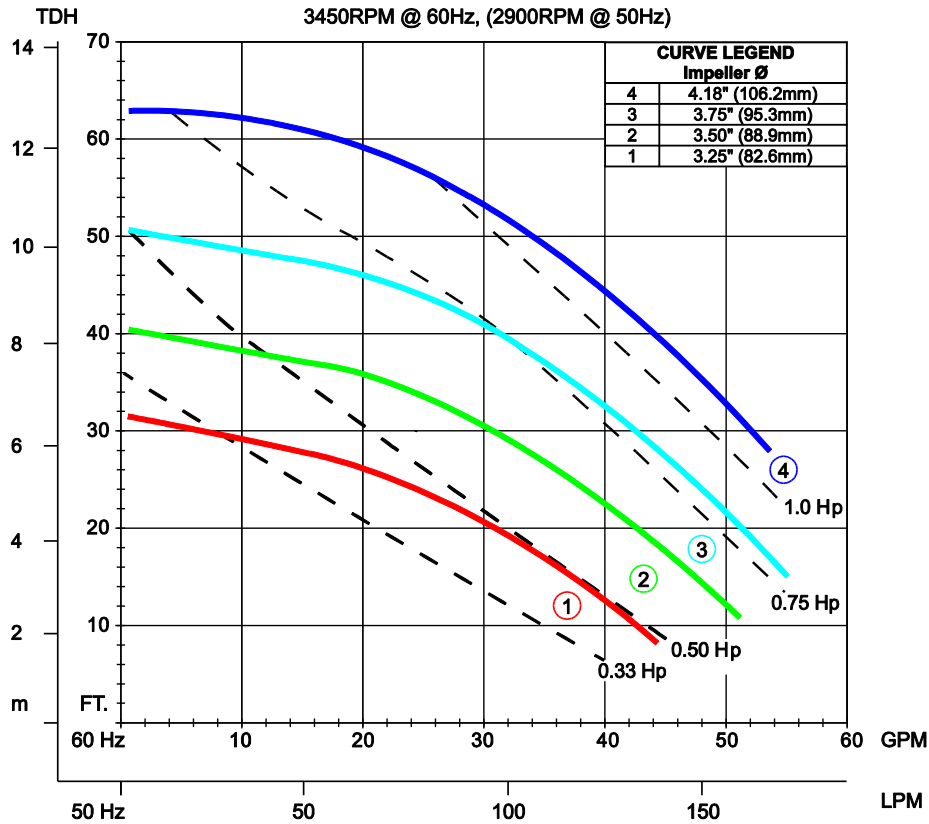

MAXIMUM LIFT 3450 RPM, 1.0 SPG		
CURVE	1" SUCTION	1-1/2" SUCTION
4	25' (7.6m)	25' (7.6m)
3	20' (6.1m)	20' (6.1m)
2	20' (6.1m)	15' (4.6m)
1	15' (4.6m)	15' (4.6m)

ORDERING INFORMATION

For standard 60HZ pump-motor combination, select model from TABLE I
For custom pump-motor combination, select from components in TABLE II

TABLE I Select pump-motor model or flow curve number providing the desired performance

FLOW CURVE	POLYPROPYLENE PUMP/MOTOR		PVDF PUMP/MOTOR		* Motor HP shown will handle full flow to a S.G. of:
	MODEL NUMBER	PRICE CODE	MODEL NUMBER	PRICE CODE	
1	MESMPVGC1B-C.75	51-2412-C	MESMKVGC1B-C.75	51-2512-C	1.50
2	MESMPVGC2B-C.75	51-2422-C	MESMKVGC2B-C.75	51-2522-C	1.19
3	MESMPVGC3B-D.1.0	51-2432-K	MESMKVGC3B-D1.0	51-2532-K	1.25
4	MESMPVGC4C-D1.5	51-2443-L	MESMKVGC4C-D1.5	51-2543-L	1.15

TABLE II To determine pump-motor for a specific flow, TDH, HP curve (dotted line) and then horizontally to HP scale. and/or specific gravity, select flow/pressure point on performance curve (solid line). Required HP is determined by moving vertically to corresponding HP curve (dotted line) and then horizontally to HP scale. Multiply indicated HP by specific gravity of fluid to be pumped. Select pump materials and construct Model and Price Code.

EXAMPLE:	PUMP	+	IMPELLER	+	MAGNET/FRAME	+	MOTOR	=	PCN
	MESMPVGC	+	3	+	B	+	D1.0	=	51-2432-K

- 1. For pump only, eliminate motor suffix from price code number.
- 2. Single phase – 115-208-230V/1/60 or 110-220V/1/50
Three Phase – 208-230-460V/3/60 or 220-380V/3/50

PUMP ¹	
MODEL NO.	PCN
MESMPVGC Polypropylene	51-24
MESMKVGC PVDF	51-25

IMPELLER		
FLOW CURVE	ADD TO	
	MODEL	PCN
1	1	1
2	2	2
3	3	3
4	4	4

	MAGNET SET / FRAME SIZE				MOTOR ²				
	HP/KW	MAGNET SET	FRAME SIZE	ADD TO		SINGLE PHASE		THREE PHASE	
				MODEL	PCN	MODEL	PCN	MODEL	PCN
60 Hz	.5	6 POLE	56C	A	1	-C.5	A	-D.5	G
	.75	8 POLE	56C	B	2	-C.75	C	-D.75	J
	1.0	8 POLE	56C	B	2	-C1.0	D	-D1.0	K
	1.5	10 POLE	56C	C	3	-C1.5	E	-D1.5	L
	2.0	10 POLE	56C	C	3	-	-	-D2.0	P
	.33/.25	6 POLE	63FR	A	4	-	-	DM.25	Q
	.5/.37	6 POLE	71FR	A	5	-	-	DM.37	V
	.75/.55	8 POLE	71FR	B	6	-	-	DM.55	W
	1.0/.75	8 POLE	80FR	B	7	-	-	DM.75	X
	1.5/1.1	10 POLE	80FR	C	8	-	-	DM1.1	Y

OPTIONAL

DESCRIPTION	ADD OR CHANGE MODEL	ADD TO PCN
O-ring: (Change V in Model) EPDM	-L	1
Bushing: (Change C in Model) Teflon	-T	T
Alumina Ceramic	-R	R
Connections:		
BSP Threads	-B	B
Union	-U	U
Flange	-F	F

DESCRIPTION	ADD OR CHANGE MODEL	ADD TO PCN
Specials:		
SiC (bushing, thrust ring, shaft)	-S	S
Hastelloy shaft	-H	H
Titanium hardware	-M	M
Non-Sparking ring	-N	N
Exp Motor		
Also requires Non-sparking ring	-X-N	XN

DIMENSIONS

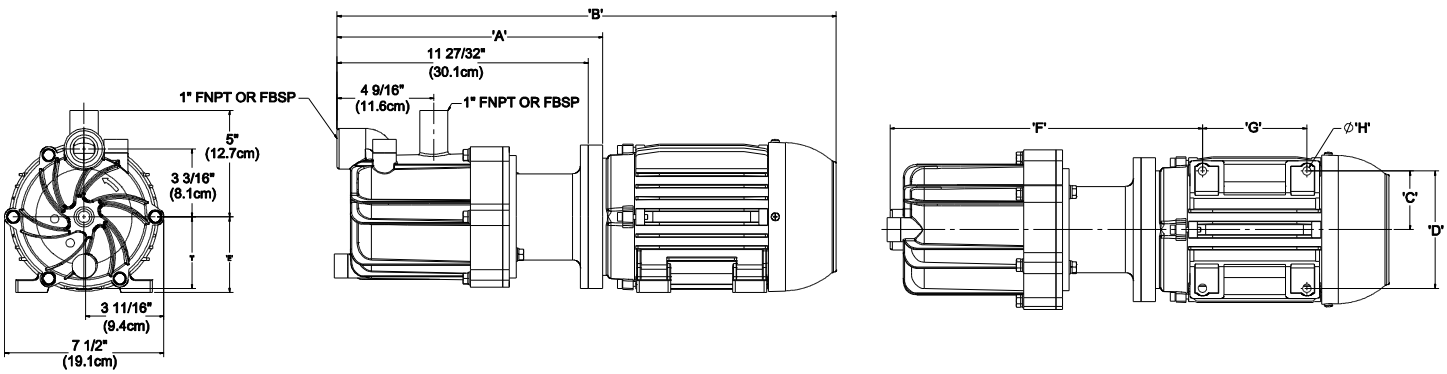

Dimensions and weights are for reference only

FRAME	A	B*	C	D	E	F	G	H	I	Pump Wt.	Motor Wt.**
	Inch (cm)									Lbs (kg)	
NEMA 56C	11-27/32" (30.1)	22-3/32" (56.1)	2-7/16" (6.2)	4-7/8" (12.4)	3-1/2" (8.9)	14-19/32" (37.1)	3" (7.6)	11/32" (0.9)	3-3/8" (8.6)	13 (5.9)	28 (12.7)
NEMA 145TC	11-27/32" (30.1)	23-1/16" (58.6)	2-3/4" (7.0)	5-1/2" (14.0)	3-1/2" (8.9)	14-7/32" (36.1)	5" (12.7)	11/32" (0.9)	3-3/8" (8.6)	13 (5.9)	32 (14.5)

* Varies with motor manufacturer.

** Depends upon motor manufacturer and style of motor chosen.