

A Comparison of the Monty Roberts Technique with a Conventional UK Technique for Initial Training of Riding Horses

Veronica Fowler*, Mark Kennedy† and David Marlin‡

**Institute for Animal Health, Guildford, UK*

†*Department of Life Sciences, Anglia Ruskin University, Cambridge, UK*

‡*Department of Physiology, Oklahoma State University, Stillwater, USA*

Address for correspondence:
Dr Veronica Fowler,
Institute for Animal Health,
Ash Road, Guildford,
Surrey GU24 0NF, UK.
E-mail:
veronica.fowler@thebrooke.org

ABSTRACT This study describes a comparison of the efficacy of the Monty Roberts horsemanship technique (MRT) in comparison with a UK conventional training technique (CT) for the initial training of horses. The sample consisted of 14 untrained horses, between 3 and 5 years old, sourced from a variety of non-competition yards in the UK. Horses were matched on temperament and randomly assigned to either the MRT group or the CT group. Each trainer was allowed 30 minutes per day to work with each horse for 20 days, following which the horses undertook a standardized ridden obstacle and flatwork test and a ridden freestyle test. Horses were scored for technical performance by a panel of judges who were unaware of the study or the trainers involved. During the session where the first saddle and rider were achieved, MRT-trained horses had significantly lower ($p = 0.0137$) maximum heart rates (bpm \pm SD) (first saddle: 127 ± 37 , first rider: 76 ± 12) when compared with CT-trained horses (first saddle: 176 ± 24 , first rider: 147 ± 61). MRT-trained horses had similar mean heart rates to CT-trained horses (91 ± 15 bpm, 80 ± 7 bpm, respectively) during the ridden obstacle test but received significantly higher performance scores from the judges (171 ± 4 , 133 ± 7 , respectively; $p < 0.0001$). MRT horses had similar mean heart rates to CT horses (81 ± 13 , 93 ± 5 , respectively) during the ridden flatwork test but were awarded significantly higher scores by the judges (149 ± 9 , 121 ± 11 , respectively; $p = 0.0005$). Thus, the efficacy of the MRT for initial training of riding horses is greater than that of the CT.

A Comparison of the Monty Roberts Technique with a Conventional UK Technique...

Keywords: equitation, heart rate, horse, Join-up[®], lunging, training



Initial training of young horses has been recently documented as a substantial stressor with respect to the welfare of the horse (Schmidt et al. 2010). Despite this, horse training within the United Kingdom, and indeed the world, is still not protected by the law and thus is a largely unregulated profession that one can join without any formal education and practical experience. This is of great concern from both a welfare and ethical perspective since it has been documented that even professional trainers can lack understanding of animal learning theory and how it should be implemented in animal training (Warren-Smith and McGreevy 2006). The result of which may in part be responsible for the alarmingly high wastage of horses euthanized due to behavioral problems (Odberg 2005).

Horses are known to be capable of a range of different types of learning (Cooper 2007; Goodwin 2007; Heitor and Vicente 2007; Murphy and Arkins 2007). However, regardless of the cultural or geographic origin, or indeed the term used to describe the type of horsemanship technique, the two main categories of learning applicable to most training systems in the world today are non-associative (habituation and sensitization) and associative learning (classical and operant conditioning) (McGreevy 2007). Considering the capabilities of horses to learn and thus be trained, significant steps forward in terms of providing guidelines for ensuring the improvement of horse training, and thus reducing non-ethical equitation, have begun and have been facilitated by the establishment of the International Society for Equitation Science (ISES) (Randle 2010).

Training techniques, for example, which are believed to limit the occurrence of behaviors indicative of “conflict” (such as rearing, bucking, bolting, biting, kicking), (Quick and Warren-Smith 2009) or to be more “sympathetic” to the horse (Fureix et al. 2009; Visser et al. 2009) have been studied. Murphy (2007) demonstrated that the use of an automated horse walker during initial training (preparing a horse to accept a saddle and rider) can reduce conflict behavior (such as bucking) either in response to being saddled or mounted for the first time, whereas Quick and Warren-Smith (2009) demonstrated less conflict behavior during initial training using bitless as opposed to bitted bridles. Fureix et al. (2009) studied the difference in emotional reactivity of horses trained by “traditional” horsemanship techniques when compared with “natural” horsemanship techniques. The authors found that although both types of training decreased the occurrence of vocalization during fear eliciting situations, the traditionally trained horses were less likely to approach a motionless person than the naturally trained horses. In another study, Visser et al. (2009) compared “compassionate” training (which included groundwork, long-lining, desensitization, and the gradual process of mounting a rider) with “traditional” training (which included lunging, long-lining, and mounting of a rider using a predefined schedule), demonstrating that although there was no difference in the performance of the horses in a ridden assessment following training, the horses trained with a more compassionate approach expressed significantly less fear and stress-related behavior and lower heart rates than traditionally trained horses at the end of their training.

Studies have also indicated certain horse training techniques/equipment which may be considered significant stressors. These include the use of punishment (McGreevy and McLean 2009), hyperflexion of the horse’s neck (rollkür), the use of conflicting signals simultaneously (i.e., leg and rein pressure), the use of one cue for two different behavioral responses (i.e., rein pressure for deceleration and neck flexion) (McGreevy 2007; McLean and McGreevy 2007), and lunging (Schmidt et al. 2010). Other techniques such as rapping, gingering, soring, reducing behavioral reactivity via anesthesia/water deprivation, electric shock collars, horse walkers, training reins,

correction bits, martingales, tight nosebands, whips, spurs, and hobbles are also identified as threats to welfare and problematical in terms of learning theory (McLean and McGreevy 2010a).

Another area of concern is the use of the round pen and the interpretation of horse and human behavior within this training environment (Kruger 2006; Goodwin et al. 2009; McGreevy et al. 2009; McGreevy and McLean 2010). Concern surrounding the use of the round pen is associated with the argument that this technique induces fear and provokes the flight response (McGreevy and McLean 2007). Authors have suggested that because fear responses have been documented to be less prone to extinction (Le Doux 1994) and subject to spontaneous recovery (McGreevy and McLean 2006), these behaviors should not be encouraged as part of training (McGreevy and McLean 2007; McLean and McGreevy 2010a, 2010b). However, as yet there have been no studies undertaken in order to investigate these claims. In a recent study, specific behavioral patterns associated with the round pen technique have been defined (Krueger 2006). These include licking, chewing, and stretching, which in the case of chewing and stretching appear to be correlated with the time at which the horse follows the handler. However, because this technique appears to be generalized to unfamiliar trainers and that the horses neglected to continue following the trainer outside the round pen, the authors suggested that this technique had no efficacy in developing a leadership bond between horse and handler. Instead, the authors suggested that this technique may simply teach the horse how to avoid being chased (Krueger 2006). In this respect, the round pen technique may be similar to the conventional training technique of lunging. Horses within a round pen are encouraged to move forwards by the pressure of a long line being flapped against the leg of the trainer. This method is similar to the following of the horse on the lunge with the lunge whip and thus may represent pressure which the horse is motivated to move away from. In lunging, when the horse complies in the manner the trainer requires, the pressure is either removed or decreased by movement of the lunge whip away from the horse. During the round pen technique, when the horse performs the chewing and neck stretching reported by Krueger (2006), the driving stops and the horse turns in towards the trainer. Both are examples of operant conditioning through negative reinforcement; it is the removal of the pressure by the trainer when the desired behavior is performed that increases the future probability of performance of that behavior (Mills and Nankervis 1999). However, despite these similarities it is currently unknown or at least debatable to what extent the various pressures used in round pen training actually result in the horse becoming fearful, as opposed to simply being motivated to move away from the pressure.

The list of training methods and equipment which are suspected of compromising horse welfare is ever increasing. However, evaluative, supporting scientific literature in this area is still lacking. Indeed, there are currently only four papers which have specifically evaluated methods employed in initial horse training (Murphy 2007; Fureix et al. 2009; Visser et al. 2009; Schmidt et al. 2010).

The purpose of this study was to evaluate the efficacy of the Monty Roberts horsemanship technique (MRT) in comparison with a conventional United Kingdom training technique (CT) for initial training of riding horses. Our working null hypotheses were:

- 1) There will be no difference in the heart rate responses (bpm) of the MRT and CT horses during 20 days of initial training including specific time points of first saddle and first rider.
- 2) There will be no difference between the MRT and CT horses in the time (units of time) taken for each horse to accept its first saddle and then first rider.
- 3) There will be no difference in the ridden performance or heart rate (bpm) between the MRT and CT horses during a ridden assessment following their training program.

A Comparison of the Monty Roberts Technique with a Conventional UK Technique...

Methods

Horses and Husbandry

Fourteen untrained horses were sourced from a variety of yards in the UK. All horses were between 1.57 meters and 1.67 meters high at the withers. The group consisted of four mares and 10 geldings and were of various breeds: Warmblood ($n = 7$); Warmblood \times Irish Draught ($n = 1$); Thoroughbred \times Irish Draught ($n = 1$); Andalusian ($n = 1$); Oldenberg ($n = 1$), and Welsh Section D ($n = 3$). All horses were between 3 and 5 years old. In the context of this study, untrained was taken to mean that they had been trained to accept a halter but had not been saddled, fitted with a bridle, mounted, or ridden.

The horses were transported from their homes to Sparsholt College (Hampshire, UK) two days prior to the start of the study, and on arrival each was assigned an identity number (1–14) via a tag which was clipped onto the nearside of the head collar. They were stabled in an American barn containing 18 identical stables (12 m \times 12 m) which had front grilles (not including the area over the door) with solid brick backs and sides and rubber mats. The horses were given wheat straw and had ad libitum access to water and good quality soaked hay. Once a day, the horses received 100 grams of high fiber nuts. In addition, after arrival all mares received Regu-mate[®] (Intervet) (1ml per 50 kg/day/orally). This is a synthetic progestin (altrenogest) which is used to inhibit estrus-associated behavior. Regu-mate[®] was used to ensure that the performance of the mares in either training group was not influenced by estrus-associated behavior (there was the potential that one trainer could have all his mares demonstrating estrus-associated behavior and the other trainer not having any). In this study, no estrus-associated behavior was observed either before or during administration of Regu-mate[®]. One way to avoid this scenario would have been to use many more horses over an extended period of training time; however, this was outside the scope of this study. In addition, due to facilities at Sparsholt College only being available for sole use for a period of three weeks, all horses within this study received the digestive conditioning supplement Succeed[®] (one tube/once a day), in order to help reduce the risk of digestive problems associated with change in environment and routine.

Exercise prior to the commencement of the study consisted of two sessions of 10 minutes turnout per day in the indoor arena where training was to subsequently take place. During the study, the only exercise the horse received was during its daily 30-minute training session. Stables were mucked out only when the horse was absent from its stable, that is, during training.

Allocation of Horses to Trainers

Horses were matched based on their performance during a handling and novel object test before being randomly assigned to either the MRT group or the CT group. Both trainers were given the opportunity to see all 14 horses trotted up in hand in the main arena. During this time, each trainer independently scored each horse for its difficulty in handling whilst in the main arena: 1 = handler in control, horse walks around outside track of arena; 2 = handler in control, horse walks with episodes of trotting around the outside of arena; 3 = handler in partial control, horse mostly trots around outside arena with episodes of circling in trot around handler; 4 = handler not in control, handler is unable to lead the horse around the outside of the area, horse mainly trots and canters in circles around handler; and 5 = handler not in control, horse canters with episodes of gallop in circles around handler. Both trainers then worked together to match the horses based on their score for each horse during this assessment.

In order to test the accuracy of the matching and the random allocation to either training method, each horse was brought individually back into the main arena where they were exposed to a novel object. The object used was a large blue and white umbrella. Two ground poles were placed 2 meters apart. The same umbrella handler was used for all horses and stood behind the second pole facing the first pole, with the umbrella in a closed position with the tip touching the ground. Each horse was brought into the arena and was positioned so that its front feet were less than half a meter away from the first of the two poles. Once the horse was standing still in front of the poles and facing the umbrella, the umbrella was lifted to the horizontal and opened and closed once very quickly and returned to its starting position. Each horse was then scored by one of the investigators blinded to the trainers' pairings on its reaction to the umbrella: 1 = no discernable reaction; 2 = startled but did not move away; 3 = stepped backwards; 4 = jumped away; 5 = extreme reaction. Statistical analysis revealed that there was no significant difference in the novel object test scores of the horses randomly allocated to the MRT and CT groups (Mann-Whitney test; $U = 46.50$, $p = 0.73$). This non-significant result demonstrates an excellent pairing of horses and thus an equal distribution in terms of reactivity of horse to trainer. Following this result, one horse from each pair was then randomly assigned to each trainer (Table 1). Each horse was then examined by a veterinarian to confirm they were clinically healthy.

Table 1. Behavioral reactivity of the 14 horses to a novel object (sudden opening of an umbrella). Horses were scored on a scale of 1–5 (1 = no discernable reaction; 2 = startled but did not move away; 3 = stepped backwards; 4 = jumped away; 5 = extreme reaction).

	Behavioral Reactivity	
	MRT	CT
Pair 1	4	5
Pair 2	4	4
Pair 3	5	5
Pair 4	4	4
Pair 5	2	2
Pair 6	4	4
Pair 7	3	3
Median	4	4
Min.	2	2
Max.	5	5

MRT = Monty Roberts technique; CT = conventional technique.

Trainers

Trainers were selected in order to represent two differing styles of training horses. Monty Roberts (MR) represented his own techniques (MRT) whilst Phil Roelich (PR), a British Horse Society registered horse trainer (qualified to BHS preliminary teaching level, also holding National Vocational Qualifications in Horse Care and Horse Management), represented the conventional technique (CT) and has been successfully training horses professionally for 12 years. Each trainer was required to prepare a detailed guide to their method of starting horses which was approved by the Sparsholt College Ethics Committee prior to the start of the study, and

A Comparison of the Monty Roberts Technique with a Conventional UK Technique...

neither trainer was permitted to use any training technique or equipment which had not been detailed in their specified methods. In addition, each trainer was only permitted to interact with their allocated horses during their 30 minutes of daily training time in the arena; they were not permitted to enter the stables at any time during the study, or to observe each other working. A single nominated assistant worked with each of the trainers and was subject to the same restrictions applied to the trainer.

Horse Handlers

Six horse handlers, who remained the same throughout the study were assigned to handle horses when being led from the stable to the training arena and from training arena back to the stable. Investigators ensured that each handler handled horses in both groups, alternating between a MRT and a CT horse. The handlers were not permitted to interact with the horses at any time other than to put their head collars on, brush straw from their manes and tails, pick out feet, and lead the horses to the indoor arena. Horse handlers were strictly monitored by the investigators at all times to ensure that no unintentional training was given.

Heart Rate Recording

Heart rate during the daily training sessions and the final assessments was recorded using a Polar RS800CX system (Polar Electro, Finland). Heart rate monitors were started prior to handing the horse to the trainers and were stopped immediately following the horse being handed back to the handler. They were set to record the heart rate averaged every five seconds. All other functions were disabled. Polar Pro Trainer Equine Edition, Version 5.35.161 was used for analysis.

Video Recording

Two scaffold platforms (approximately 2 meters) were assembled in the indoor arena to allow the camera operators to capture all horse and trainer movements. All training sessions and the two assessment days were filmed by the same two video camera operators throughout the study. Horses were not filmed on their route from the stables to the indoor arena. Video recording commenced as the horse entered the indoor arena and continued until the horse exited the indoor arena. This was done so that the heart rate trace could be synchronized with the video footage.

Habituation of Horses to the Indoor Arena and Wearing of Heart Rate Monitors

Prior to the commencement of this study, the horses were habituated to the indoor arena (23.5 m × 60 m, with cushion track) and also to the wearing of a heart rate monitor: they were turned loose in the indoor arena for 10 minutes wearing the heart rate monitor apparatus on the two evenings preceding the start of the study.

Random Assignment of Training Sessions to Trainers

In order to ensure each trainer had an equal amount of morning and afternoon training sessions, the trainers were randomly assigned either morning or afternoon sessions. MR was randomly assigned the morning session whilst PR was randomly assigned the afternoon session. On day 10, the sessions were swapped so that MR then trained in the afternoons whilst PR trained in the morning session.

Training Equipment

MR requested the following equipment: Round pen, Dually halter, long-lines, dummy rider, dummy legs, giddy-up rope (plaited rope one meter in length), girth, western saddle, stirrups and stirrup leathers, saddle pad, bridle, reins, Monty Roberts eggbutt snaffle bit, breast plate, side reins, pacifiers, wood tapper, life sized dummy rider, buckstopper, umbrella, clippers, and

plastic bag on stick. PR requested the following equipment: lunging cavesson, lunge whip, saddle, bridle, reins, girths, lunge line, long lines, numnah, breast plate, side reins, eggbutt snaffle bit, stirrups, stirrup leathers, and a 6-foot turnout rug. Both trainers had access to all of the equipment they listed from the first day of training.

Training Sessions

The procedure for each horse was the fitting of the heart rate monitor surcingle in the stable, followed by leading the horse to the indoor arena by one of the horse handlers. Upon entering the indoor arena, the horse was halted so that the heart rate monitor watch could be set to record and attached to the surcingle. Once the heart rate monitor was recording, the horse was then led towards the trainer and handed over. The location of transfer of the horse between handler and trainer was marked using a letter attached to the side of the arena wall and thus was consistent for each trainer throughout the study. The training session started as soon as the trainer was in receipt of the horse. Every person except for the trainer and the trainer's assistant exited the arena. Upon completion of the training session, the horse was handed back to the horse handler and the heart rate monitor stopped and removed. Each trainer was allocated 30 minutes training with each horse per day, with 5 minutes turnaround between horses. The horses were trained for 20 consecutive days, followed by the ridden obstacle test on day 21 and the ridden flatwork test on day 22. The use of methods and equipment by both trainers varied between horses to suit the horse's individual needs. The CT trainer trained and rode all his horses. Whilst the MRT trainer trained the horses, they were not ridden by him but by his assistant who rode all horses in training sessions and tests.

Trainer Briefing of Assessment Days to Include Ridden Flatwork Plan and Obstacle Course

In order to objectively assess the outcome/success of each training method, three "tests" were designed. One test consisted of a ridden flatwork plan to resemble a simple dressage test, one consisted of a defined obstacle course, and the third was a ridden freestyle test. At the beginning of the study, each trainer was provided with information regarding the protocol of the three tests and the structure of the two assessment days. The trainers were provided with the flatwork plan with annotations to show changes of gait. In addition, they were provided with details of the specific obstacles they would need to attempt to train for and the layout of the obstacle test. The trainers were permitted access to the obstacles from the first day of training. Two members of staff were responsible for obtaining and setting out the obstacles the trainers required. The trainers were also informed that acceptance of first rider was defined as being ridden in walk in the round pen, for the MRT, and in a circle on the lunge in the arena, for the CT group. Leaning over the back, simply sitting on the horse's back, or being led while ridden were not considered as demonstrating acceptance of first rider.

Standardized Ridden Obstacle Test: The ridden obstacle test consisted of eight obstacles and 17 tasks (Figure 1). Before the start of the study, each trainer was asked to identify what they considered to be three easy tasks, two medium tasks, and three hard tasks. These tasks were then pooled by the investigators to form the ridden obstacle test, which was provided to both trainers prior to commencement of training. The ridden obstacle test therefore consisted of combined obstacles identified by both trainers, thus removing any possible bias toward either trainer or training technique. The MRT trainer's chosen obstacles were: ridden in walk between two parallel poles (EASY), ridden in walk around three cones arranged in a triangle (EASY), walk

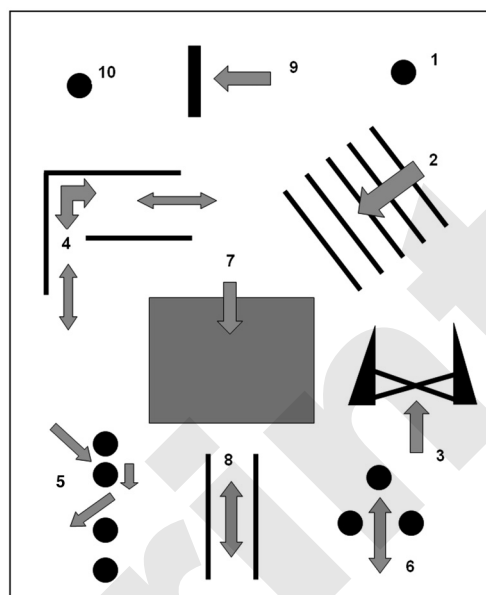

Figure 1. Arena layout for ridden obstacle test. Key to figure: 1) Mounting block; 2) Poles (walk) a-one pole, b-three poles, c-five poles; 3) jump (from trot); 4) L shape (walk) a-forwards, b-backwards; 5) Weaving cones a-walk, b-trot; 6) Clover leaf (walk) a-forwards, b-backwards; 7) Tarpaulin (walk); 8) Parallel poles (walk) a-forwards, b-backwards; 9) Curtain (walk) a-open, b-closed; 10) dismount.

between L-shaped poles (EASY), reverse between parallel poles (MEDIUM), reverse between L-shaped poles (MEDIUM), reverse around three cones arranged in a triangle (HARD), ride across blue tarpaulin (HARD), and walk through strips of tape hanging vertically (HARD). The CT trainer's chosen obstacles were: trot over one trotting pole (EASY), weave through four cones in walk (EASY), dismount unaided (EASY), stand unaided to mount and remain stationary for 3 seconds (MEDIUM), trot over three trotting poles (MEDIUM), jump a 0.5-meter cross pole (HARD), trot over five trotting poles (HARD), and weave through four cones in trot (HARD).

Prior to the start of the obstacle test, each horse was subjected to 8 minutes of warm-up time. The horses were not permitted to enter the area of the indoor arena where the obstacles were set out during the warm-up and were only permitted to warm up in a sectioned-off "warm up" area. One trotting pole was available to the trainer in the warm-up area. Each horse had to trot over the pole at least once and no more than five times. Upon entering the obstacle area, each horse was asked to walk in a straight line along the long edge of the school and then proceed straight to obstacle one. The start of the obstacle test course was marked with flour, and time started when the horse passed this point. Each obstacle was performed by every horse and each trainer in the same order. One minute per obstacle was allowed and any horse not completing in 1 minute was considered as a fail for that task. Any obstacle not attempted was considered a fail. Each obstacle element (17 in total) had a maximum score of 10 points available and a further maximum of 10 marks were available for "overall willingness and obedience," with the obstacle test having an overall maximum score of 180 points. The trainers were provided with the score sheet by which their horse's performance would be judged (Table 2).

Standardized Ridden Flatwork Test: The flatwork test consisted of a ridden test similar to a Preliminary British Dressage test (Figure 2). Prior to the start of the flatwork test, the rider was allowed 8 minutes of warm-up time with the horse in the indoor arena. The warm-up time was monitored and strictly enforced. The ridden flatwork test had a maximum of 170 points available, 10 points per task. The same rider who had ridden the horses throughout the training rode during the test. This was to ensure that performance was not limited by the novelty of a different rider not aware of the riding aids the horses had been taught during the two differing training regimens. The trainers were provided with the score sheet by which their horse's performance would be judged (Table 3).

Freestyle Test: Immediately following the ridden flatwork test, each trainer was allowed a period of 12 minutes to demonstrate other skills that they had trained their horses to perform, in addition to those of the ridden obstacle and flatwork tests. This took place in the same arena as the ridden flatwork test. The freestyle test was not standardized, unlike the ridden obstacle and ridden flatwork tests: MR was present in the video footage when his assistant presented the horses. MR's presence was essential to the demonstration of what other skills MRT horses possessed. Heart rates were not recorded during this test, due to it not being a standardized test. Judges scored for willingness (indicated by completion of the task and responsiveness [how quickly the task was performed following the ridden aid]). Because each trainer could have shown a different range and number of additional skills, there was a maximum score of 100 points available regardless of how many extra skills the trainers demonstrated. The judges were instructed to score the overall performance of the horse during this time period rather than each individual task.

Judges

A panel of six independent judges was used to represent eventing, dressage, western, and show jumping disciplines. Judges were asked to score video footage rather than be present during the assessment days. Each judge was provided with a score sheet containing explanations of how to score each test (Tables 2 and 3). In order to prevent bias amongst the judges (knowing that MR was involved in the study), all MRT horses were presented and ridden by his assistant in the standardized ridden tests. In addition, both MRT and CT horses were ridden in similar English tack, as opposed to the normal Western tack used by the MRT. Judges were first asked to score the two standardized tests (ridden flatwork followed by the ridden obstacle test) followed by the scoring of the unstandardized freestyle test. The authors have no reason to believe that the judges were aware of the identity of either trainer until after the ridden obstacle and ridden flatwork tests had been scored.

Scoring of Tests

The following instructions were provided to the trainers at the start of the study to explain how the judging would be carried out: "You will be judged based on the willingness and obedience of your horse. The horse should be moving forward freely but also not pulling against the bit. You should be able to change speed and direction without hesitation, confusion, or resistance from your horse. You should ride corners and turns accurately. The horses are not expected to maintain any particular frame or shape. To keep subjectivity to a minimum you will be judged largely on the accuracy of your test—changing pace and direction in the correct places—this will be taken as a sign of your horse's obedience to the aids." In addition, the judges score sheets were provided to each trainer (Tables 2 and 3).

A Comparison of the Monty Roberts Technique with a Conventional UK Technique...

Table 2. Ridden obstacle test scoring instructions for judges.

	Score				
	10	9	8	7	6
1) Mount 3 seconds of stillness	No assistance no movement	One step once mounted	Assisted but not held	Takes one step forward or back before mounting	Max. score if held. Two steps once mounted
2) Poles a) 1 b) 2 c) 3	Straight, forward, calm trot		Not straight		Runs off course, initially hesitates
3) Jump	Even rhythm, straight, calm and willing	Leaps, too big, loses rhythm	Not straight on approach	Slows considerably or touches pole	Over excited, bucks on landing
4) L Shape a) forwards b) backwards	Smooth, no rushing, no touch	Touched poles Slight hesitation	Steps over pole once	Very wobbly, but completes	Resisting sides, but completes
5) Cones a) walk b) trot	Even rhythm, smooth, calm	Breaks pace briefly		Touching a cone	Misses a cone
6) Clover Leaf a) forwards b) backwards	Smooth, tight to the cones, accepting bit	Slight resistance or hesitation	Touches cone		
7) Tarpaulin	No change in rhythm	Not straight	Hesitates or breaks	Rushes	
8) Parallel Poles	No touches, straight, calm, willing	Touches or hesitates	Once step over but corrected	Very wobbly, much hesitation	Runs out the end of the poles
9) Curtain a) open b) closed	No change to rhythm, calm and straight	Slight change of pace. Flinch	Slight hesitation	Stops or breaks pace	Backs off
10) Dismount	Total stillness	Looks tense	One step		
11) Overall willingness and obedience	Smooth, accepting, willing and calm	Slightly distracted	Not always straight	Some resistance or evasion	Head throwing, mouth open

Table 2. continued

Score					
5	4	3	2	1	0
	Has to be represented to block, avoids block	Walks forward or back as mounted	Repeatedly has to be represented		Cannot be mounted
Jumps poles, rushes fast	Obviously reluctant but does complete	Runs out or stops			Cannot complete
Hesitates stringly, stops way out but then goes on to jump	Refuses or runs out once but jumps when represented	Refuses or runs out twice	Refuses or runs out 3 or more times	Rearing, running backwards or spinning around	Cannot complete
Max. score if partially completed	Steps forward against the bit when backing	Moves against leg	Strongly resisting aids, some attempted back steps	Severe head tossing, rearing, spinning, running backwards	Cannot complete
Knocks over cone. One refusal	Pulling against bit, not moving forward	Two refusals	Three refusals	Running off, loss of control	Cannot complete
Moves towards leg aid and not away. Not smooth	Attempts to back up	Knocks cone over	Scared of cones	Rear, spook, spin, run back	Cannot complete
					Cannot complete
Resisting aids, only back partially	Runs out the side of the poles	Strong resistance to back up		Runs backwards, rears, spins, or won't enter poles	Cannot complete
	Resists strongly	Blasts through quickly		Runs backwards, rears, spins, or won't enter	Cannot complete
	Horse needs to be held		Running off, loss of control		Cannot complete
		Small buck or nap	Lack of control	Running off, loss of control	Cannot complete

Table 3. Ridden flatwork test scoring instructions for judges.

Movement	Score					
	10	8	6	4	2	0
Circles	Smooth circle, maintains round shape, circle is correct size, pace is even, horse only requires quiet aids	Some changes in rhythm, circle not quite round, some hesitation in responding to aids, circle slightly too big or small	Horse breaks pace briefly, some small resistances to aids, horse needs stronger aids, circle not consistent shape, or perfect circle but in wrong pace	Horse breaks pace for longer, circle is much too small or big, or in wrong place in arena. Horse throws head, resists aids strongly, looks strong or lazy	Some attempt at a circle shown. Napping, severe resistances to aids, horse looks confused or unwilling or frightened	Cannot complete or not attempted
Transitions	Horse moves immediately from one pace to another with the rider exactly on the marker as pace is changed. Horse does not resist aids at all. Horse remains straight and calm through transition. Rhythm is even and transition looks smooth not hurried.	Transition smooth but slightly too late or too early Transition in the correct place but tense, not calm or not straight	Slight resistances or confusion to aids. Head thrown up, tail clamped Transition 4 or more strides after marker	Stronger resistances to the aids Transitions 6 or more strides after the marker	Transition eventually made but with rushing, confusion, continued resistance to the aids Horse not at all on the track or straight when transition is made	Cannot complete or does not attempt
Straight Lines and Corners	Horse works well into the corners and up to the markers. Horse moves straight, calm, smoothly and with rhythm. Horse is moving forwards freely but not pulling against the bit	One slight change in rhythm. Horse distracted or slightly spooks. Horse briefly leaves track or is not entirely straight through movements. Horse looks soft and willing but is not sticking to the track or riding to the markers	More changes in rhythm or bigger changes in rhythm. Horse leaves track more regularly or more severely	Change in pace. More severe spooks, resistances to aids. Lines are not straight. Horse is rushing, pulling against bit or resisting leg aids	As to the left but more severe. Horse does not ride on track consistently for any period of time. Horse in the wrong gait. Horse fighting aids strongly or showing conflict such as napping bucking or rearing	Cannot complete or does not attempt

A Comparison of the Monty Roberts Technique with a Conventional UK Technique...

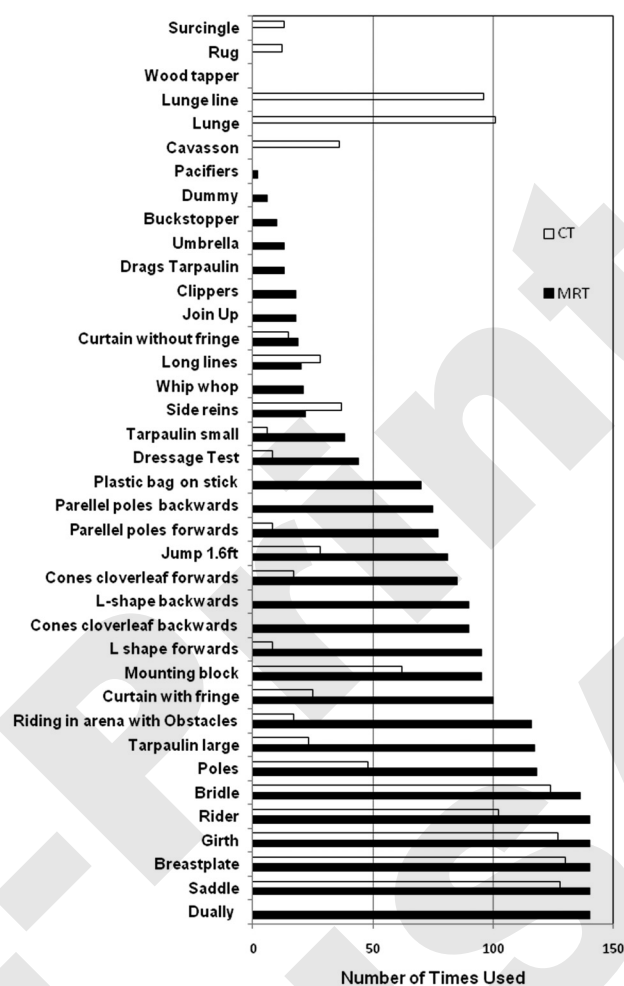

Figure 3. Total number of times that each piece of equipment was used in the implementation of the Monty Roberts technique (MRT) and the conventional technique (CT) during the 20 days of training.

outside of the round pen. Components of the ridden obstacle and ridden flatwork test had also been introduced to training sessions. All CT horses had been saddled, bridled, and lunged during the early training phase, and all but one horse had been ridden for the first time. Components of the ridden obstacle and ridden flatwork test had not yet been introduced to training sessions.

During both the mid (days 8–14) and late (days 15–20) training phases, all of the MRT horses were being ridden freely around the arena. All components of the ridden obstacle and ridden flatwork test were now being included in the MRT training sessions and being ridden as per the test. In contrast, all but one (ridden for the first time on day 9) of the CT horses were being ridden freely around the arena. During the mid-phase but not the late phase of training, CT horses were briefly lunged for less than 10 minutes prior to being ridden. Components of the ridden obstacle and ridden flatwork test had also been introduced to training sessions, however, at no point throughout the 20 days of training did CT horses practice either test in its complete form.

The bridle, rider, girth, breastplate, and saddle were used a similar number of times by each trainer, however, the Dually halter and Join-up[®] were used frequently by the MRT but not at all by the CT, whereas lunging and lunge lines were used frequently by the CT but not at all by the MRT (Figure 3).

Effect of Training Technique on Acceptance of First Saddle

All seven horses trained by the MRT were saddled on day 1. None of the horses trained by the CT were saddled on day 1; six horses were saddled on day 2 and the remaining horse on day 3.

The minimum, mean, and maximum heart rates (mean \pm SD) of the MRT horses during first saddle (and subsequent session of Join-up[®]) were 52 ± 11 , 84 ± 24 , and 127 ± 37 bpm, respectively, whilst for CT horses during first saddle (and subsequent session of lunging) they were 51 ± 7 , 106 ± 15 , and 176 ± 24 bpm, respectively. CT maximum heart rates during lunging with first saddle were significantly higher than maximum heart rates of the MRT ($t = 2.885$, $p = 0.0137$) (Figure 4). Mean heart rates of the CT horses during lunging with first saddle were higher than those of the MRT horses, although these were not significantly different (t -test, $p > 0.05$).

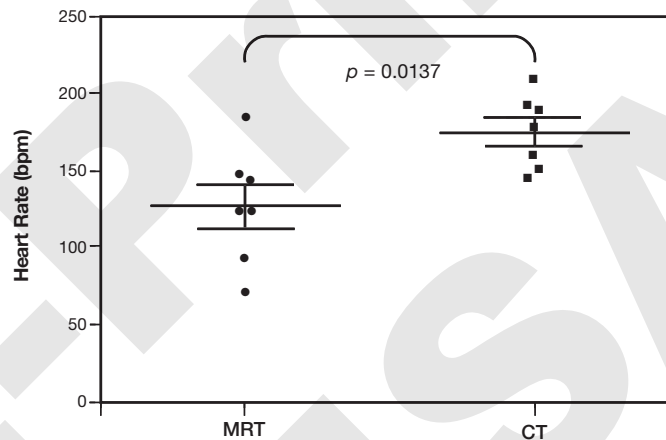

Figure 4. Maximum heart rate during first saddle. Solid line represents the mean maximum heart rate (bpm) and error bars represent the standard deviation. MRT = Monty Roberts technique; CT = conventional technique.

Effect of Training Technique on Acceptance of First Rider

All seven horses trained by the MRT accepted their first rider on day 1. In the CT group, three horses accepted their first rider on day 4, two horses on day 5, and the remaining two horses on days 7 and 9.

The minimum, mean, and maximum heart rates (mean \pm SD) during first rider for the MRT horses were 67 ± 14 , 71 ± 14 , and 76 ± 37 bpm, respectively. For the CT horses, they were 57 ± 13 , 99 ± 34 , and 146 ± 61 bpm, respectively. Maximum heart rates of the CT horses during first rider were significantly higher than the maximum heart rates of the MRT horses ($t = 3.014$, $p = 0.0108$) (Figure 5). There was also a trend for the mean heart rates of the CT horses during first rider to be higher than those of the MRT horses, although these were not significantly different (t -test, $p > 0.05$).

A Comparison of the Monty Roberts Technique with a Conventional UK Technique...

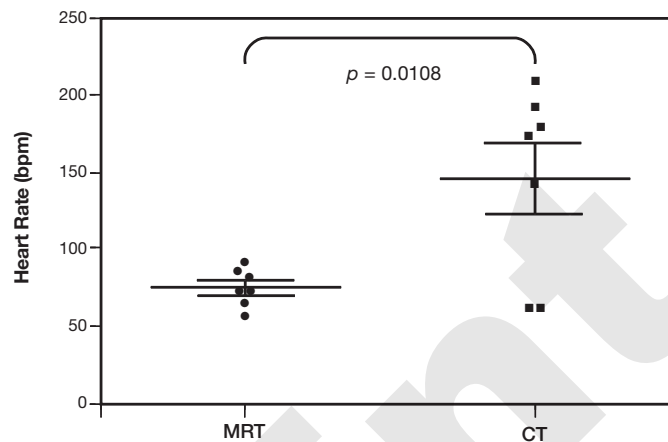

Figure 5. Maximum heart rate during first rider. Solid line represents the mean maximum heart rate (bpm) and error bars represent the standard deviation. MRT = Monty Roberts technique; CT = conventional technique.

Heart Rate during 20 Days of Training

The minimum, mean, and maximum heart rates (mean \pm SD) for horses trained over days 1 to 20 by the MRT were 36 ± 4 , 85 ± 7 , and 167 ± 10 bpm, respectively, and for horses trained by the CT, 38 ± 5 , 83 ± 7 , and 162 ± 14 bpm, respectively. There was no significant difference between either MRT- or CT-trained horses in minimum, mean, or maximum heart rates (General Linear Model ANOVA, $p > 0.05$) throughout training.

As heart rates varied according to activity and as different horses progressed through their training at different rates, the mean and maximum training heart rates were also grouped for early (days 1–7), mid (days 8–14), and late (days 15–20) training periods. Mean heart rates (mean \pm SD) for the MRT and CT horses were 91 ± 8 versus 84 ± 12 bpm (early), 83 ± 4 versus 85 ± 2 bpm (mid), and 82 ± 6 versus 81 ± 3 bpm (late), respectively. Maximum heart rates for the MRT and CT horses were 172 ± 11 versus 171 ± 19 bpm (early), 166 ± 8 versus 158 ± 8 bpm (mid), and 161 ± 9 versus 155 ± 8 bpm (late), respectively. There was no significant effect of training period (early, mid, or late) on mean or maximum heart rates (General Linear Model ANOVA, $p > 0.05$).

Heart Rate and Performance of Horses during the Ridden Obstacle Test

Two of the CT horses were not entered for the obstacle assessment as in the trainer's opinion they had not progressed enough in their training for it to be a safe task to undertake. The scores of these horses (i.e., zero) were not included in the statistical analysis. In addition, none of the CT horses which were entered had been successfully trained to back-up as this is not a common practice of the CT in horses less than a year into their training. Therefore any obstacles requiring a back-up were not attempted and were scored as zero for this task.

The minimum, mean, and maximum heart rates (mean \pm SD) for horses trained by the MRT were 34 ± 7 , 91 ± 15 , and 155 ± 26 bpm, respectively, and by the CT were 35 ± 4 , 80 ± 6 , and 150 ± 15 bpm, respectively. There were no statistical differences (t -test, $p > 0.05$). However, MRT-trained horses (judges score: 171 ± 2) scored significantly higher for performance than did CT-trained horses (judges score: 133 ± 4) ($t = 3.076$, $p < 0.0001$; Figure 6).

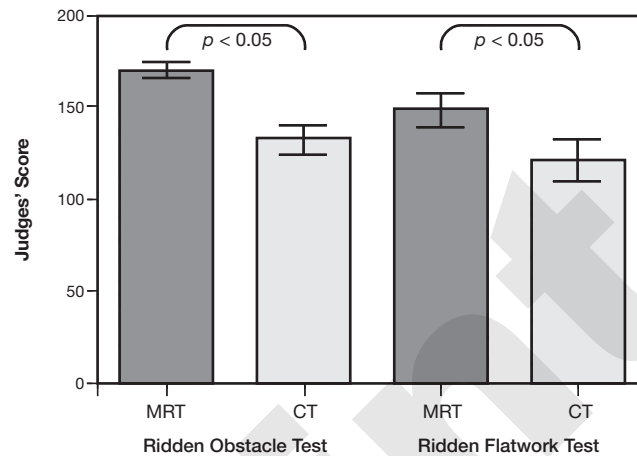

Figure 6. Mean judges' scores (\pm SD) for the horses (trained using either the Monty Roberts technique [MRT] or the conventional technique [CT]) during the ridden obstacle test (MRT $n = 7$, CT $n = 5$) (maximum score 180) and the ridden flatwork test (MRT $n = 7$, CT $n = 6$) (maximum score 170).

Heart Rate and Performance of Horses during the Ridden Flatwork Test

One of the CT horses was not entered for the ridden flatwork test as in the trainer's opinion it had not progressed enough in its training for it to be a safe task to undertake. The score of this horse (i.e., zero) was not included in the statistical analysis. The minimum, mean, and maximum heart rates (mean \pm SD) for horses trained by the MRT were 33 ± 4 , 81 ± 13 , and 155 ± 24 bpm respectively, and for CT 39 ± 13 , 93 ± 5 , and 171 ± 27 bpm, respectively. There were no significant differences (t -test, $p > 0.05$). MRT-trained horses had significantly lower (General Linear Model ANOVA, $p < 0.001$) minimum heart rates during the flatwork test when compared with any other MRT or CT training day. In addition, MRT-trained horses (judges' score: 149 ± 9) scored significantly higher for performance than CT-trained horses (judges' score: 121 ± 11) ($t = 2.462$, $p < 0.0005$; Figure 6).

Performance of Horses during the Freestyle Test

All seven MRT-trained horses and six CT-trained horses were presented for the freestyle test. At this point in the study, the judges became aware that Monty Roberts was involved as he presented his own horses. MRT-trained horses (judges' score: 92 ± 4) scored significantly higher for performance than CT-trained horses (judges' score: 71 ± 11) ($t = 3.829$, $p = 0.0004$).

Discussion

The mounting of a rider onto the back of a horse is a human–horse interaction to which there is no equivalent horse–horse analogue (McGreevy et al. 2009). Since domesticated horse behavior is reported to resemble closely that of wild horse behavior (Christensen and Rundgren 2008), it could be suggested that horses may perceive the mounting of a rider as equivalent to the attack of a predator and thus an extremely fear eliciting event. The recent work by Schmidt et al. (2010) strongly supports this hypothesis: they demonstrated that the mounting of a rider caused a significant decrease in beat to beat (R-R) intervals (representative of an increase in heart rate) and heart rate variability (HRV), which is indicative of psychological stress

when in isolation from the effects of exercise (Visser et al. 2002; Reitman et al. 2004). This research strongly suggests that the initial training used for the mounting of a rider is a procedure which should be undertaken with extreme care. Despite this, the literature is considerably lacking in this area of study, with very few papers (Murphy 2007; Fureix et al. 2009; Visser et al. 2009; Schmidt et al. 2010) specifically evaluating initial horse training methods. As a consequence, no clear guidelines as to the most appropriate and ethical method for initial training of riding horses currently exist.

Effect of Trainer and Trainability of Horse on the Rate of Training

When evaluating the effectiveness of two different initial training methods, it is important to first consider the three main factors which will ultimately determine the success of a particular training program: the trainability of the horse, the competency of the trainer, and the appropriateness of the techniques used. In this study, differences were noted between the MRT and the CT in the rate of training and performance of the horses during ridden tests and thus one or more of these factors could have been responsible for these observations.

With regard to trainability, the horses used in this study were behaviorally matched before being randomly allocated to the trainers. As such, there is no reason to suspect discrepancies in trainability of the horses in the MRT and CT groups. With respect to the competency of the trainer, both trainers in this study had a 100% success rate in saddling and riding their horses, the only difference being the time taken to achieve this. In the case of the CT horses, which took longer to accept their first saddle, it is possible that this occurred due to the trainer having only 12 years of experience as compared with more than 50 years in the case of Monty Roberts. However, it should be remembered that greater experience does not necessarily dictate a higher level of competency. This would, however, be worth ruling out in a future study which could involve trainers of the same number of years of experience and/or competency. Another possibility for the differences noted in the rate of training and performance of the horses is directly related to the style of CT. It is not uncommon for conventional styles of training to take between 8 to 10 days before the horse can start to be ridden, as it requires the horse to be lunged and in some cases long lined on both reins before introduction of saddle and rider (Quick and Warren-Smith 2009; Visser et al. 2009). Overall, therefore, we have no reason to believe that trainer competency had an influence on the outcome of this study.

The fact that CT did not sufficiently train all seven horses in time to be presented for the ridden tests is most likely related to the later time point at which these horses were saddled, and thus the trainer had less time to prepare these particular horses for the ridden tests. We are confident that the differences observed in this study are strongly related to training technique and not due to the other variables outlined above. It would be of interest in a future study to assess psychological parameters and performance of horses during ridden assessments when all horses had reached the same level of training.

Effect of Training Technique on the Heart Rate of Horses during First Saddle and First Rider

Initial training of horses has recently been documented as a significant stressor, with lunging and first rider correlating with the largest increases in heart rate and reductions in R-R intervals (Schmidt et al. 2010). In the current study, mean heart rates of CT horses were increased at time of first saddle and rider when compared with the mean heart rate during 20 days of training, echoing the results of both Visser et al. (2009) and Schmidt et al. (2010). However, this was in contrast to the mean heart rates of MRT-trained horses, which despite being

saddled and ridden for the first time on day 1, were the same during first saddle and less for first rider when compared to the mean heart rate during 20 days of training. This observation is of particular interest as in the few studies which have evaluated heart rate, there has not yet been a documented case whereby heart rate is lower at time of first rider when compared with first saddle or total weeks in training (Visser et al. 2009; Schmidt et al. 2010). These results indicate that the MRT facilitates learning, beyond that of the CT, of the horse to accept a saddle and rider on its back. This suggests that the methods used by the CT at key events, such as first saddle and first rider, may provoke increases in heart rate and inhibit the process of learning. Indeed, this suggestion is validated further by the fact that CT horses' maximum heart rates were significantly higher than those of the MRT horses during both first saddle and first rider.

Lunging, which has long been a method of concern (Goodwin et al. 2009; McGreevy and McLean 2010; McLean and McGreevy 2010a), and recently documented as a significant stressor during initial training of horses (Schmidt et al. 2010), was used by the CT during first saddle and also in the study by Visser et al. (2009) but never used by the MRT. Therefore, the use of lunging may be strongly associated with the increases in heart rate observed in the CT horses, rather than the saddling process itself (fitting of saddle pad, saddle, breastplate, and girth). Lunging may also have been responsible for the increases in heart rate in CT horses observed during first rider, since although it was not used during the analysis period, it had been used immediately prior to first rider in all cases. Indeed, in a recent study evaluating the use of bitted and bitless bridles during an otherwise conventional style of foundation training, heart rates were lower in both cases than those seen in CT horses—the only substantial difference being that these authors used long lining rather than lunging during the preparation period for first rider (Quick and Warren-Smith 2009).

Concerns also exist over the use of the round pen and in particular Join-up[®] due to this technique being likened to lunging in terms of its potential to provoke the flight response (McGreevy and McLean 2007). In addition, Krueger (2007) questioned the usefulness of this technique in facilitating human–horse leadership. In this study, we could not find any evidence to suggest that the use of the round pen or indeed the practice of Join-up[®] caused increases in heart rate which would be of concern with regard to the welfare of the horse. In fact, the minimum, mean, and maximum heart rates of horses during Join-up[®] without a saddle were 62 ± 14 , 103 ± 28 , and 136 ± 42 bpm, respectively, and during their first saddle were 52 ± 11 , 84 ± 24 , and 127 ± 37 bpm. The heart rates observed were considerably below the estimated maximum heart rate for horses of this age and breed (around 220 bpm; Vincent et al. 2006). In addition, although there are differences in the saddling and mounting procedures in current published studies, when considering heart rates recorded during first saddle and first rider, the MRT horses had the lowest reported for any training regime published to date (Quick and Warren-Smith 2009; Visser et al. 2009). We accept, though, that this result may differ given an inexperienced trainer using Join-up[®] for the initial training of their horse, thus the effect of it practiced by various levels of trainer competency warrants further study. In addition, in the present study only one measure of physiological/psychological stress, that is, heart rate was measured. We are therefore reluctant to make strong inferences about the welfare of horses trained using the two techniques since it is not possible to completely isolate the influence of workload and anxiety on measured heart rates (Physick-Sheard et al. 2000). A further study using a range of measures of welfare, such as HRV, conflict behaviors, and salivary cortisol levels is required to enable firmer conclusions on the relative effect of the techniques on welfare to be drawn.

A Comparison of the Monty Roberts Technique with a Conventional UK Technique...

Effect of Training Technique on Performance and Heart Rate during Ridden Tests

In this study, the MRT horses performed significantly better than the CT horses in both the standardized and freestyle tests. Increased performance in the ridden flatwork test was also associated with a significantly lower minimum heart rate for the MRT horses. These findings demonstrate again that opportunities for learning were greater within the MRT group: the complete test was practiced several times in advance of the test day for all MRT horses and thus these horses had more opportunity to learn the task. This is in contrast to the CT horses, who only performed the ridden test in its complete form on the day of the test. Thus, these horses could be less psychologically and physiologically prepared in comparison with the MRT horses.

Although the judges were aware of Monty Roberts' involvement during the scoring of the freestyle test, it is interesting to note that the percentage increase of the MRT scores above the CT scores were similar for the ridden obstacle test (+29%) and the ridden flatwork test (+22%)—where the judges did not know the trainers' identities—and the freestyle test in which they did (+30%). This study demonstrates that training horses using the MRT results in horses with greater technical performance abilities at the end of 20 days training. However, a future study where horses are tested once they all reach the same level of training would be of value, in order to determine if the increase in performance is a maintained characteristic of the MRT or whether this observation is only apparent during early training.

Conclusion

The MRT and the CT are both methods which can be used successfully for initial training of riding horses. However, the MRT appears to be more effective than the CT for initial training of riding horses, as demonstrated by significantly lower maximum heart rates during first saddle and first rider, and significantly higher performance scores during standardized ridden tests following 20 days of training.

Acknowledgements

We acknowledge the financial support provided by SUCCEED[®] Digestive Conditioning Program[®], Cavallo Horse and Rider Inc., and Röwer & Rüb Export GmbH. We thank Polar Equine for supplying heart rate monitors, Falcon Equine Feeds Ltd for supplying the feed for the horses, and Intelligent Horsemanship for providing hospitality to Monty Roberts during the study. We thank Sparsholt College, in particular, the yard manager Mr Stephen Jones, for the use of their excellent facilities. We also thank the anonymous reviewers for their invaluable advice in the preparation of this manuscript. Finally, we are deeply indebted to all the volunteers who gave up their time to make this study possible, and to the owners who allowed their horses to be used.

References

- Christensen, J. W. and Rundgren, M. 2008. Predator odour per se does not frighten domestic horses. *Applied Animal Behaviour Science* 112: 136–145.
- Cooper, J. J. 2007. Equine learning behaviour: Common knowledge and systematic research. *Behavioural Processes* 76: 24–26.
- Fureix, C., Pagèsb, M., Bona, R., Lassalle, J. M., Kuntzc, P. and Gonzalezd, G. 2009. A preliminary study of the effects of handling type on horses' emotional reactivity and the human–horse relationship. *Behavioural Processes* 82: 202–210.
- Goodwin, D. 2007. Equine learning behaviour: What we know, what we don't and future research priorities. *Behavioural Processes* 76: 17–19.

- Goodwin, D., McGreevy, D., Waran, N. and McLean, A. 2009. How equitation science can elucidate and refine horsemanship techniques. *The Veterinary Journal* 181: 5–11.
- Heitor, F. and Vicente, L. 2007. Learning about horses: What is equine learning all about? *Behavioural Processes* 76: 34–36.
- Krueger, K. 2007. Behaviour of horses in the “round pen technique.” *Applied Animal Behaviour Science* 104: 162–170.
- Le Doux, J. E. 1994. Emotions, memory and the brain. *Scientific American* 6: 32–39.
- McGreevy, P. D. 2007. The advent of equitation science. *The Veterinary Journal* 174: 492–500.
- McGreevy, P. D. and McLean, A. N. 2006. Ethological challenges for the working horse and the limitations of ethological solutions in training. Paper presented at the Second International Equitation Science Symposium, Milan, Italy, September 19–20, 2006.
- McGreevy, P. D. and McLean, A. N. 2007. Roles of learning theory and ethology in equitation. *Journal of Veterinary Behavior* 2: 108–118.
- McGreevy, P. and McLean, A. 2009. Punishment in horse-training and the concept of ethical equitation. *Journal of Veterinary Behavior* 4: 193–197.
- McGreevy, P. D. and McLean, A. N. 2010. *Equitation Science*. Oxford: Wiley-Blackwell.
- McGreevy, P. D., Oddie, C., Burton, F. L. and McLean, A. N. 2009. The horse–human dyad: Can we align horse training and handling activities with the equid social ethogram? *The Veterinary Journal* 181: 12–18.
- McLean, A. N. and McGreevy, P. D. 2010a. Horse training techniques which may defy the principals of learning theory and compromise welfare. *Journal of Veterinary Behavior* 5: 187–195.
- McLean, A. N. and McGreevy, P. D. 2010b. Capping the price horses pay for human glory. *Journal of Veterinary Behavior* 5: 203–209.
- Mills, D. and Nankervis, K. 1999. *Equine Behaviour: Principles and Practice*. Oxford: Blackwell Science.
- Murphy, J. 2007. An innovative approach to equitation foundation training (backing the horse) within an automated horse walker may reduce conflict behavior in the horse. Paper presented at the Third International Equitation Science Symposium, Michigan, USA, August 13–14, 2007.
- Murphy, J. and Arkins, S. 2007. Equine learning behaviour. *Behavioural Processes* 76: 1–13.
- Odberg, F. O. 2005. The evolution of schooling principals and their influence on the horses welfare. Paper presented at the First International Equitation Science Symposium, Melbourne, Australia, August 26–27, 2005.
- Physick-Sheard, P. W., Marlin, D. J., Thornhill, R. and Schroter, R. C. 2000. Frequency domain analysis of heart rate variability in horses at rest and during exercise *Equine Veterinary Journal* 32: 253–262.
- Quick, J. S. and Warren-Smith, A. K. 2009. Preliminary investigations of horses’ (*Equus caballus*) responses to different bridles during foundation training. *Journal of Veterinary Behavior* 4: 169–176.
- Randle, H. 2010. Ethical equitation—A sustainable approach. *Journal of Veterinary Behavior* 5: 167–169.
- Rietmann, T. R., Stuart, A. E. A., Bernasconi, P., Stauffacher, M., Auer J. A. and Weishaupt, M. A. 2004. Assessment of metal stress in Warmblood horses: Heart rate variability in comparison to heart rate and selected behavioural parameters. *Applied Animal Behaviour Science* 88: 121–136.
- Schmidt, A., Aurich, J., Mostl, E., Muller, J. and Aurich, C. 2010. Changes in cortisol release and heart rate and heart rate variability during the initial training of 3-year-old sport horses. *Hormones and Behaviour* 58: 628–636.
- Vincent, T. L., Newton, J. R., Deaton, C. M., Franklin, S. H., Biddick, T., McKeever, K. H., McDonough, P., Young, L. E., Hodgson, D. R. and Marlin, D. J. 2006. Retrospective study of predictive variables for maximal heart rate (Hrmax) in horses undergoing strenuous treadmill exercise. *Equine Veterinary Journal* 36(Suppl.): 146–152.
- Visser, E. K., VanDierendonck, M., Ellis, A. D., Rijkssen, C. and Van Reenen, C. G. 2009. A comparison of sympathetic and conventional training methods on responses to initial horse training. *The Veterinary Journal* 181: 48–52.
- Visser, E. K., Van Reenen, C. G., Van der Werf, J. T. N., Schilder, M. B. H., Knaap, J. H., Barneveld, A. and Blokhuis, H. J. 2002. Heart rate and heart rate variability during a novel object test in young horses. *Physiology and Behaviour* 76: 289–296.
- Warren-Smith, A. K. and McGreevy, P. D. 2006. An audit of the application of the principals of equitation science by qualified equestrian instructors in Australia. Paper presented at the Second International Equitation Science Symposium, Milan, Italy, September 19–20, 2006.