



newhorizon

Pulsed Heat Reflow Soldering System



KEY FEATURES

- Compact and flexible standard systems for high quality connections
- Ideal price-performance (throughput) ratio
- Robust frame construction
- User friendly system configuration including optional plug & play modules
- Pulsed Heat process control proven technology through Uniflow-4 Power Supply
- Included in standard system configuration:
 - X-Y Thermode Planarity Adjustment
 - Electronic System Control
 - Pneumatic Bond Head
 - Digital Bond Force Readout
- Active integrated cooling for heavy duty cycles
- CE Approved

Pulsed Heat Reflow Soldering is a selective soldering process where two pre-fluxed, solder-coated parts are heated with a thermode to a sufficient temperature to melt the solder. After this the parts are cooled below the solidification temperature to form a permanent electro-mechanical bond. The newhorizon Hot Bar systems are an integral part of the MIYACHI EAPRO Hot Bar series using Pulsed Heat technology through the Uniflow-4 power supply, a pneumatic bond head and customized 2-D & 3-D thermodes.

The newhorizon product range includes various models with different product handling features such as linear slides and rotary tables. The systems are designed considering ergonomic standards offering maximized production output. All process parameters are embedded into the system, ensuring consistent process quality and operator independence.

The newhorizon systems enable full automatic process control with manual (un-)loading of parts. Each system can be adapted to suit the customer's technical requirements through extension with optional plug & play modules. All modules are mounted on a robust frame construction. The system offers the best stability supporting applications down to the finest pitch.

TYPICAL APPLICATIONS

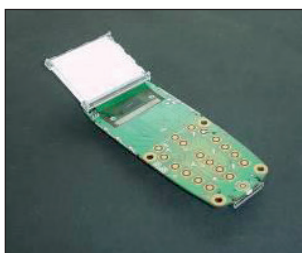

Flex soldering

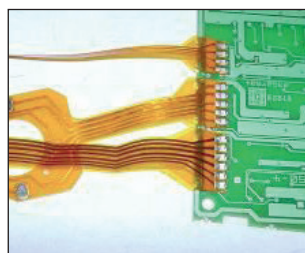

Multiple flex bonding

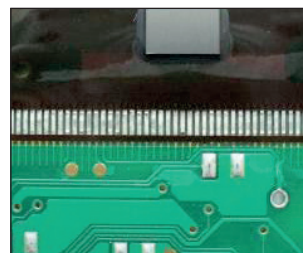

Flex bonding



Wire soldering



TECHNICAL SPECIFICATIONS

Power requirements	100-240 VAC / Single Phase / 50/60 Hz (16 Amps max)
Air supply	6 – 8 bar [87 – 116 psi] , clean dry & filtered air
Fixture assembly baseplate dimensions	150 x 150 mm
Fixture weight	1,0 kg Max (per product fixture)
Thermode size (length x width) [2-D / 3-D configuration]	[2-D: up to 50,0 x 3,0 mm] [3-D: up to 75,0 x 4,0 mm]
Starting operation	Two hand control
Operating temperature	15 – 40 °C
Operating humidity	Max 93% @ 40 °C
Certification	CE Approved

Bonding Head & Uniflow-4(*) Technical Specifications			
Force range	8 – 80 N @ 6 Bar / 60 – 750 N @ 6 Bar (applicable for both MHBR and MHSB models)		
Bond Head stroke (max)	45 mm		
Bond level height	40 mm		
Free Z space for components	20 mm		
Temperature range			
Idle	25 to 300 °C	Heat	60 to 600 °C
Baseheat	25 to 300 °C	Heat Extended Range	60 to 999 °C
Preheat	60 to 500 °C	Postheat	25 to 999 °C
Time period (in 0,1 sec increments)			
Base Heat	0 to 99,9 seconds	Rise to Heat Time	0 to 9,9 seconds
Rise to Preheat Time	0 to 9,9 seconds	Heat	0,1 to 99,9 seconds
Preheat	0 to 99,9 seconds or continuous	Postheat	0 to 99,9 seconds
Communication ports	RS-232, RS-485		
(*) For additional specifications, please review the Uniflow-4 Technical Datasheet			

MODEL SPECIFICATIONS

MHBR-2100 Base	No movement
MHBR-2200 Linear Slide (manual 2-position front-rear slide)	Stroke between front and bonding position: 200 mm fixed
MHBR-2300 Rotary Table (manual 2-position)	Turntable diameter: 380 mm
MHBR-2400 Automatic Rotary Table (pneumatic 2-position)	Turntable diameter: 380 mm Turntable movement time: < 2 seconds
MHSB-3110 Base	No movement
MHSB-3210 Linear Slide (manual 2-position front-rear slide)	Stroke between front and bonding position: 200 mm fixed
MHSB-3310 Rotary Table (manual 2-position)	Turntable diameter: 380 mm
MHSB-3410 Automatic Rotary Table (pneumatic 2-position)	Turntable diameter: 380 mm Turntable movement time: < 2 seconds

WEIGHT & DIMENSIONS

Dimensions HxWxD (mm)	650 x 615 x 695 (excluding Power Supply)
Weight	60 kg (excluding Power Supply of approx. 30 kg)

IMAGES & DRAWINGS

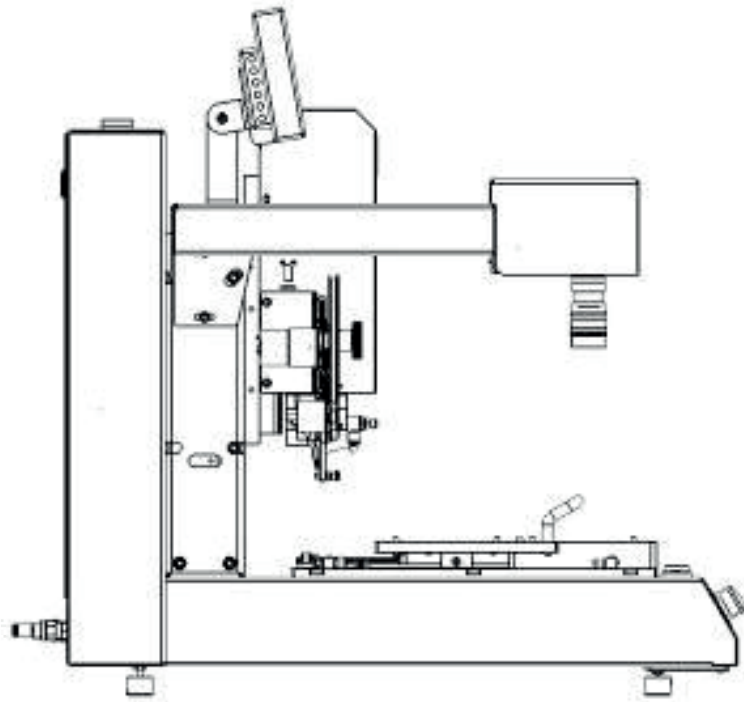
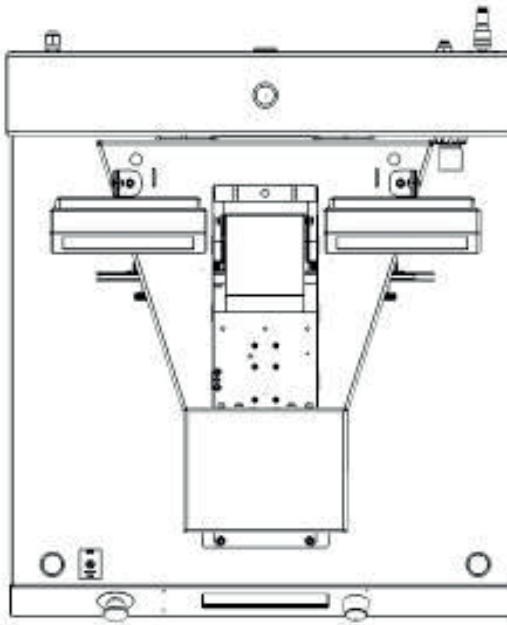
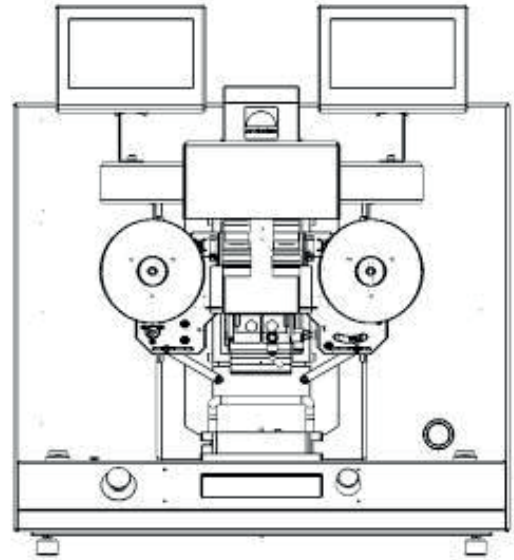
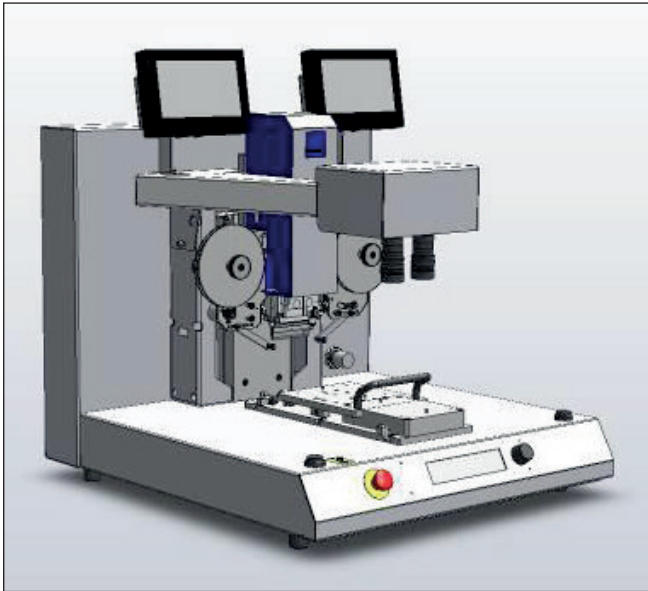

AMADA MIYACHI EUROPE

Lindberghstrasse 1 • DE-82178 Puchheim, Germany
 T: +49 (0) 89 83 94 030 • Fax : +49 (0) 89 839403 68
 info@amadamiyachi.eu • www.amadamiyachieurope.com
 ISO 9001 Certified Company

EUROPE

Amada Miyachi Europe BV
 Helmond, The Netherlands
 T: +31 (0) 492 542 225
 info@amadamiyachi.eu

Amada Miyachi Europe Kft.
 Budapest, Hungary
 T: +36 1 431 9927
 info@amadamiyachi.eu

Amada Miyachi Europe
 Derby, United Kingdom
 T: +44 (0) 1332 361 238
 info@amadamiyachi.eu

Amada Miyachi Europe
 Saint Germain en Laye, France
 T: +33 (0) 139 046 430
 info@amadamiyachi.eu

Amada Miyachi Europe
 Torino, Italy
 T: +39 011 223 83 16
 info@amadamiyachi.eu

Amada Miyachi Europe
 Prague-West, Czech Republic
 T: +420 251 512 157
 info@amadamiyachi.eu

AMERICAS

Amada Miyachi America Inc.
 Monrovia, CA, USA
 T: +1-626-303-5676
 info@amadamiyachi.com

Amada Miyachi do Brasil Ltda.
 Sao Paulo, Brasil
 T: +55-11-4193-1187
 antonio.ruiz@miyachi.com

ASIA

Amada Miyachi Co., Ltd.
 Noda, Japan
 T: +81-4-7125-6177
 sales@miyachi.com

Amada Miyachi Shanghai, Co., Ltd.
 Shanghai, China
 T: +86-21-6448-6000
 zqzhang@msc.miyachi.com

MIYACHI UNITEK | **MIYACHI P E G O** | **MIYACHI IAPRO**

Amada Miyachi Korea Co., Ltd.
 Gyeonggi-do, Korea
 T: +82-31-8015-6810
 dykim@mkc.miyachi.com

Amada Miyachi Taiwan Co., Ltd.
 Taipei, Taiwan R.O.C.
 T: 886-2-2397-4778
 keigaku@miyachi.com

Amada Miyachi (Thailand) Co., Ltd.
 Samutprakarn, Thailand
 T: +66-2751-9337-8
 info@mtl.miyachi.com

Amada Miyachi Vietnam Co., Ltd.
 Ho Chi Minh City, Vietnam
 T: +84-8-3771-7972

Amada Miyachi India Pvt., Ltd.
 Bangalore, Karnataka
 info@miyachiindia.com

follow us on:



All data, images and text are subject to change at any time. Amada Miyachi Europe GmbH reserves the right to change, modify, delete and add technical specifications and product details at any time without prior notification. © 2015 Amada Miyachi Europe GmbH.